



**Design  
Data**

**D.S. BROWN®**  
A GIBRALTAR INDUSTRIES COMPANY

**Bridges**

REV 08/14

Structural Bearing Assemblies  
**Versiflex™ HLMR Disc Bearing  
 Assemblies Multi-Directional  
 DM Series – 10%**

**Design Basis:** AASHTO 17th Edition w/ Interims – Section 14

**Rotation:** 0.02 Radians

**Horizontal Capacity:** Internal Components to Resist Friction  
 (10%), but No Accountable Resistance

**Movement:** X = As shown below  
 Y = As shown below

**Steel Strength:**  $F_y = 50$  ksi

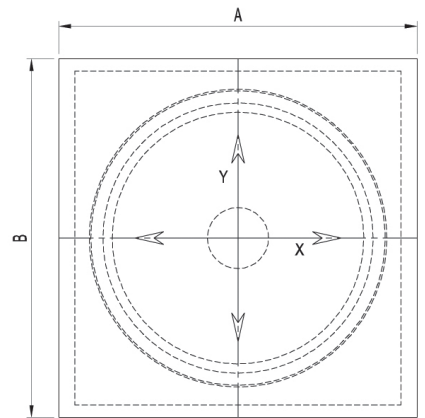
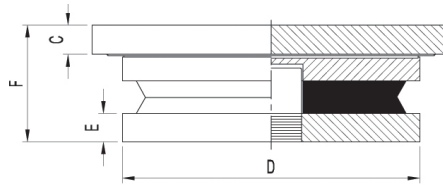

**DM SERIES- 10%**

Model Number	Vertical Capacity (Klps)	Horizontal Capacity (Klps)	Movement		A	B	C	D	E	F
			X	Y						
DM100	100	10	1	3	9.50	11.50	1.00	7.125	0.750	3.750
DM200	200	20	1	3	12.00	14.00	1.00	9.375	0.750	4.250
DM300	300	30	1	3	13.75	15.75	1.00	11.125	0.750	4.625
DM400	400	40	1	3	15.50	17.50	1.00	12.500	0.750	4.750
DM500	500	50	1	3	16.75	18.75	1.00	13.875	0.750	5.000
DM600	600	60	1	3	18.25	20.25	1.00	15.000	0.875	5.375
DM700	700	70	1	3	19.25	21.25	1.00	16.125	1.000	5.625
DM800	800	80	1	3	20.50	22.50	1.00	17.125	1.000	5.875
DM900	900	90	1	3	21.50	23.50	1.00	18.000	1.000	6.000
DM1000	1000	100	1	3	22.50	24.50	1.00	19.000	1.125	6.375
DM1250	1250	125	1	4	24.75	27.75	1.00	21.000	1.250	6.750
DM1500	1500	150	1	4	26.75	29.75	1.00	22.875	1.375	7.250
DM1750	1750	175	1	4	28.50	31.50	1.00	24.625	1.500	7.750
DM2000	2000	200	1	4	30.25	33.25	1.00	26.125	1.500	8.000
DM2250	2250	225	1	6	32.00	37.00	1.00	27.750	1.625	8.250
DM2500	2500	250	1	6	33.50	38.50	1.00	29.250	1.750	8.750
DM2750	2750	275	1	6	35.00	40.00	1.00	30.625	1.750	9.000
DM3000	3000	300	1	6	36.50	41.50	1.00	32.125	1.875	9.375

**Bridge the World with Leading Infrastructure Solutions**

## Versiflex™ HLMR Disc Bearing Assemblies Multi-Directional DM Series – 10%

### Structural Bearing Assemblies

2 of 2

#### Design Considerations

- A. Bearing assembly component dimensions are based on assumed structural conditions and a skew of 0°.
- B. Translational movements (X and Y) shown in the chart reflect total required structural movement. Bearing components are detailed to accommodate the structural movement plus a  $\pm 1$ " factor of safety.
- C. Sole plates are designed for a welded connection to a steel girder flange. Sole plate dimensions will vary for bolted connections to steel flanges and/or for bearings supporting concrete superstructure elements.
- D. Masonry plate information has been excluded from the bearing details. Masonry plate dimensions are based on the allowable bearing stress of the substructure unit and the anchorage requirements.

A recommended method of determining the masonry plate thickness is to use a 60° load distribution through the plate. The effective loaded area should be used to calculate the bending moment of the plate and the concrete bearing pressure.

