

### Structural Bearing Assemblies

## Versiflex™ HLMR Pot Bearing Assemblies Uni-Directional PMG Series - 30%

**Design Basis:** AASHTO 17th Edition w/ Interims – Section 14

**Rotation:** 0.03 Radians

**Horizontal Capacity:** 30% of Vertical Capacity

**Movement:** X = ±0.063"

Y = As shown below

**Steel Strength:** Fy = 50 ksi

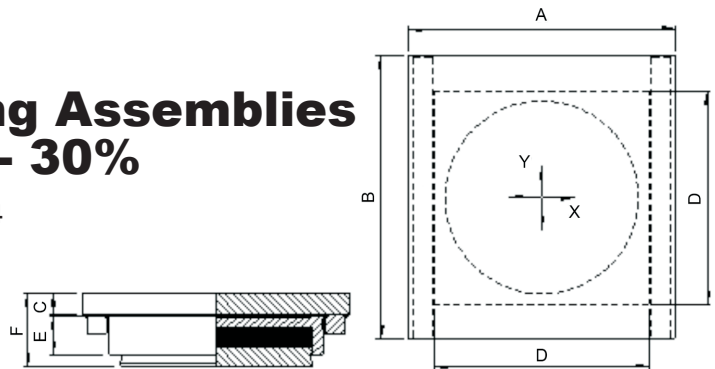

### PMG SERIES - 30%

Model Number	Vertical Capacity (Klps)	Horizontal Capacity (Klps)	Y	Dimensions (in)					
				A	B	C	D	E	F
PMG100	100	30	3	13.25	12.75	1.00	7.750	2.000	4.125
PMG150	150	45	3	15.00	14.00	1.00	9.000	2.375	4.500
PMG200	200	60	3	16.50	15.25	1.00	10.250	2.750	5.000
PMG250	250	75	3	18.00	16.25	1.00	11.250	3.000	5.125
PMG300	300	90	3	19.00	17.00	1.00	12.000	3.375	5.625
PMG350	350	105	3	20.25	18.00	1.00	13.000	3.625	5.875
PMG400	400	120	3	21.50	18.75	1.00	13.750	3.750	6.000
PMG450	450	135	3	22.50	19.50	1.00	14.500	4.125	6.500
PMG500	500	150	3	23.75	20.50	1.00	15.500	4.250	6.500
PMG550	550	165	3	24.75	21.25	1.00	16.250	4.500	6.875
PMG600	600	180	3	25.75	22.00	1.00	17.000	4.625	7.000
PMG650	650	195	3	26.75	22.50	1.25	17.500	4.875	7.625
PMG700	700	210	3	27.50	23.00	1.25	18.000	5.000	7.625
PMG750	750	225	3	28.25	23.75	1.25	18.750	5.125	7.875
PMG800	800	240	3	29.00	24.25	1.25	19.250	5.250	8.000
PMG850	850	255	3	30.00	25.25	1.25	20.250	5.500	8.250
PMG900	900	270	3	30.75	25.75	1.25	20.750	5.625	8.375
PMG950	950	285	3	31.75	26.25	1.50	21.250	5.750	8.750
PMG1000	1000	300	3	32.25	26.75	1.50	21.750	6.000	9.125
PMG1100	1100	330	4	33.75	28.75	1.50	22.750	6.250	9.250
PMG1200	1200	360	4	34.75	29.50	1.50	23.500	6.375	9.500
PMG1300	1300	390	4	36.25	30.75	1.50	24.750	6.750	10.000
PMG1400	1400	420	4	37.75	31.75	1.75	25.750	7.000	10.500
PMG1500	1500	450	4	38.75	32.50	1.75	26.500	7.125	10.625
PMG1600	1600	480	4	40.00	33.50	1.75	27.375	7.375	11.000
PMG1700	1700	510	4	41.00	34.25	1.75	28.125	7.625	11.250
PMG1800	1800	540	4	42.00	35.00	2.00	28.875	7.825	11.750
PMG1900	1900	570	4	43.50	36.00	2.00	30.000	8.125	12.125
PMG2000	2000	600	4	44.25	36.50	2.00	30.500	8.250	12.250
PMG2250	2250	675	6	46.50	40.25	2.00	32.250	8.750	12.875
PMG2500	2500	750	6	49.25	42.25	2.25	34.250	9.250	13.625
PMG2750	2725	825	6	51.25	43.75	2.25	35.750	9.625	14.000
PMG3000	3000	900	6	53.50	45.25	2.50	37.250	10.000	14.875
PMG3500	3500	1050	6	57.50	48.25	2.75	40.250	10.875	16.000
PMG4000	4000	1200	6	61.25	51.50	2.75	43.250	11.625	16.750
PMG5000	5000	1500	6	68.00	56.00	3.25	47.875	13.000	19.000

Bridge the World with Leading Infrastructure Solutions

## Versiflex™ HLMR Pot Bearing Assemblies Uni-Directional PMG Series - 30%

Structural Bearing Assemblies

2 of 2

### DESIGN CONSIDERATION

- A. Bearing assembly component dimensions are based on assumed structural conditions and a skew of 0°.
- B. Translational movements (Y) shown in the chart reflect total required structural movement. Bearing components are detailed to accommodate the structural movement plus a ±1" factor of safety.
- C. Sole plates are designed for a welded connection to a steel girder flange. Sole plate dimensions will vary for bolted connections to steel flanges and/or for bearings supporting concrete superstructure elements.
- D. Masonry plate information has been excluded from the bearing details. Masonry plate dimensions are based on the allowable bearing stress of the substructure unit and the anchorage requirements.

A recommended method of determining the masonry plate thickness is to use a 60° load distribution through the plate. The effective loaded area should be used to calculate the bending moment of the plate and the concrete bearing pressure.

