

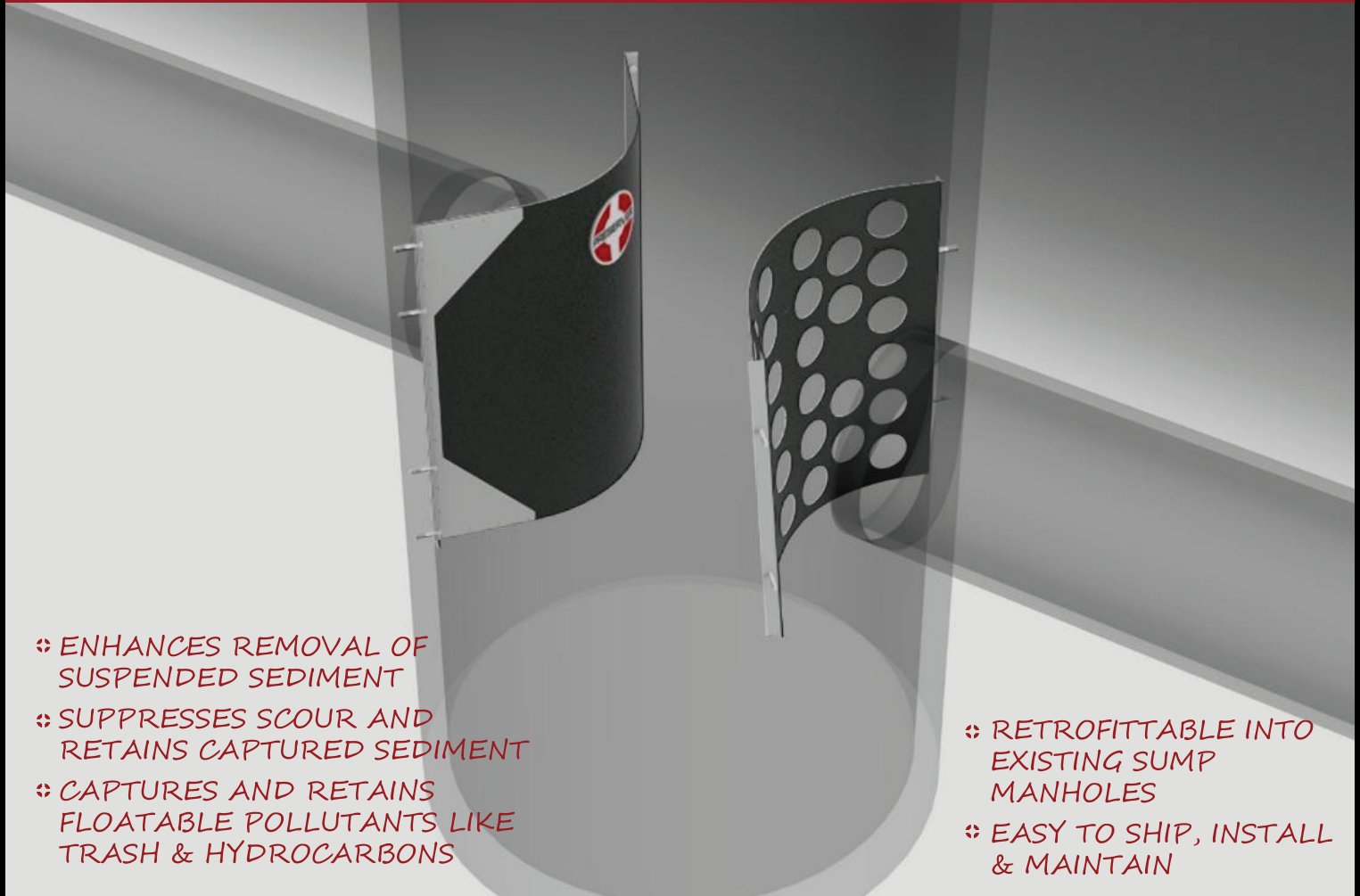

THE PRESERVER™

PATENT PENDING

A RETROFITTABLE, AFFORDABLE GRAVITY SEPARATOR



- ❖ ENHANCES REMOVAL OF SUSPENDED SEDIMENT
- ❖ SUPPRESSES SCOUR AND RETAINS CAPTURED SEDIMENT
- ❖ CAPTURES AND RETAINS FLOATABLE POLLUTANTS LIKE TRASH & HYDROCARBONS

- ❖ RETROFITTABLE INTO EXISTING SUMP MANHOLES
- ❖ EASY TO SHIP, INSTALL & MAINTAIN

USE THE THE PRESERVER™ TO:

MEET TSS REMOVAL REQUIREMENTS:

- Use as an equivalent to:
 - Gravity Separation Devices
 - Hydrodynamic separators
 - Vortex separators/concentrators
- Quantify your annual sediment removal to meet permit requirements.
- Sediment removal and retention backed by full scale, independent 3rd party laboratory testing.

REDUCE YOUR OVERALL SYSTEM MAINTENANCE COSTS:

- Collect sediment within sump manholes, not downstream BMPs:
- For example: over the long-term, pond dredging costs are 2x to 4x that of vacuuming sediment from manholes that discharge to the pond.
 - Greatly decrease your downstream BMP maintenance frequency.



SIMPLE • EFFECTIVE • AFFORDABLE • STORMWATER SOLUTIONS

PROUDLY MADE IN THE USA | **QUALITY MATERIALS:**

- 100% recycled HDPE
- Stainless steel brackets
- Stainless steel hardware

THE PROBLEM:

- Previously captured sediment in sump manholes is subject to scour during large storms. Sediment is washed downstream and the sump's intended function is diminished.
- Skimmers are effective at capturing floatable pollutants such as trash and hydrocarbons, but have the negative effect of increasing scour.
- Current devices on the market utilize swirling which exacerbates scour at high flows, or use false floors or skirts to protect previously captured sediment that reduce ease of access/maintenance.

SUMP MANHOLE

SUMP MANHOLE WITH SKIMMER

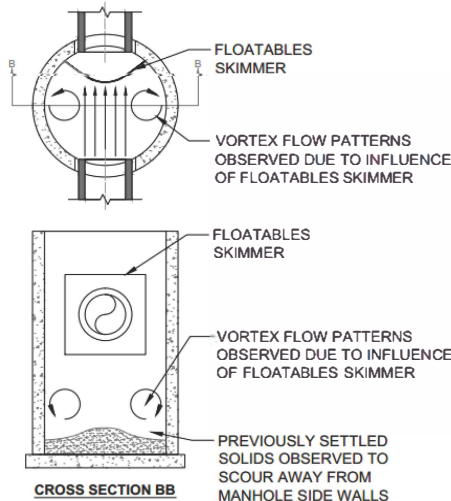
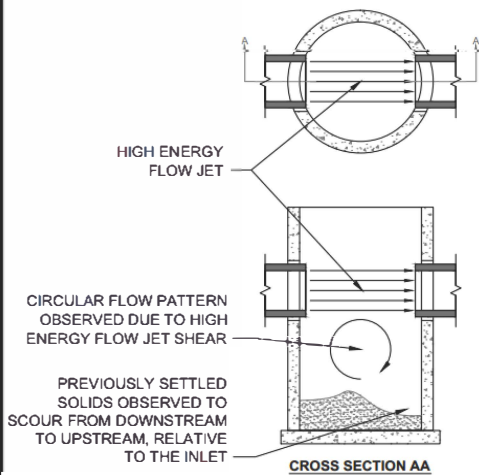

Ø24" Pipe - 8 cfs



High Energy Jet Reduces Removals and Scours Previously Captured Sediment

THE SOLUTION:

The Preserver's energy dissipator eliminates the flow patterns that cause scour in sump manholes and sump manholes with skimmers. The quiescent condition created by the dissipator allows for greater sediment removal during low flows and nearly eliminates scour during high flows.

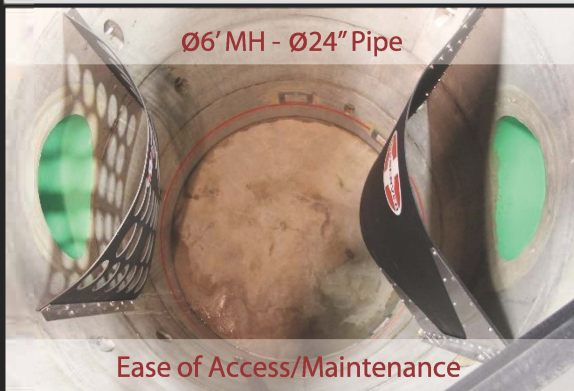

PATENT PENDING



WHY SEDIMENT RETENTION MATTERS:

Several publicly funded studies have been performed in recent years to quantify the removal and retention performance of several common gravity separation manholes. When using that data in a continuous simulation to mimic natural rainfall patterns, the results show that units designed to suppress scour perform much better on an average annual basis versus all other units tested.

Momentum
ENVIRONMENTAL

Distributed by: Bowman
Construction Supply,
Phone: (303) 696-8960

SEE HOW IT WORKS @ MomentumEnv.com

877.773.0073

SIMPLE • EFFECTIVE • AFFORDABLE • STORMWATER SOLUTIONS